

W31042
GM VORTEC 4800 V8 4.8 LITER GAS ENGINE
MARCH 25, 2009

WORKHORSE (GVW RATING 12,000 LB) CHASSIS 133" WHEEL BASE

SELECTED BODY OPTIONS

- RAILS CONFIGURED FOR 11 - 12 FT BODY (133" WB)

AXLES

- 11,000 LB. DANA M80 HYPOID REAR AXLE
- REAR AXLE 5.13 RATIO
- DUAL REAR WHEELS

SUSPENSION

- 5,000 LB. 2-STAGE PARABOLIC FRONT SUSPENSION
- 7,500 LB. 2-STAGE PARABOLIC REAR SUSPENSION

ENGINE AND TRANSMISSION

- GM VORTEC 4800 V8 4.8 LITER GAS ENGINE
- 264 HP @ 4800 RPM, 295 LB-FT TORQUE @ 4400 RPM
- GM 4L80-E ELECTRONIC 4-SPEED TRANSMISSION WITH OVERDRIVE
- FEDERAL EMISSIONS, REQUIRED FOR ALL VEHICLES TO BE REGISTERED IN FEDERAL EMISSIONS AREAS
- EMISSION SYSTEM FEDERAL, TIER 2
- EVAPORATIVE SYSTEM EMISSION
- REGISTRATION EMISSION, CERTIFICATION, FIFTY STATE
- TRANSMISSION OIL COOLER
- ENGINE ALARM

WHEELS AND TIRES

- WHEEL COLOR GRAY
- TIRE FRONT 225/70R19.5/F HWY
- TIRE BRAND FRONT - GOODYEAR
- TIRE REAR 225/70R19.5/F HWY
- TIRE BRAND REAR - GOODYEAR

BRAKES

- BREMBO 4-WHEEL DISC BRAKES (2 X 68 MM CALIPER DIAMETER)
- MERITOR WABCO 4-CHANNEL ABS SYSTEM WITH FULL J-1939 DIAGNOSTIC CAPABILITY
- FRONT & REAR ROTOR SIZE: 12.67 X 1.2 INCH DIAMETER
- MASTER CYLINDER TYPE: 1.57 INCH DIAMETER DELPHI HYDROBOOST 50/50 SPLIT SYSTEM
- BRAKE LINES: ALUMINIZED STEEL
- FLUID TYPE: DOT 3
- HAND APPLIED PARKING BRAKE
- TRANSMISSION MOUNTED DRUM TYPE SECURED WITH LOCK WASHERS & LOCTITE

- SIZE: 11 X 2.5 INCHES

COOLING

- 15.6 QUART CAPACITY CROSS FLOW RADIATOR
- 549 SQUARE INCH FRONTAL AREA X 1.34 INCH THICK WITH ONE ROW OF 34 MM WIDE CROSS FLOW TUBES
- EXTERNALLY MOUNTED EXPANSION TANK
- FAN TYPE: VISCOUS FAN DRIVE MOUNTED TO A 20 INCH 8 BLADE FAN
- THERMOSTAT: 187 DEGREES F
- MOUNTING: RUBBER ISOLATORS - (2) UPPER AND (2) LOWER
- SHROUD: TWO PIECE - PLASTIC
- HOSE TYPE: EPDM RUBBER
- ANTIFREEZE: DEX-COOL (GM 6277 M) 5-YEAR COOLANT
- FAN BELTS: SINGLE SERPENTINE FOR ACCESSORIES - INDEPENDENT A/C BELT

BATTERY

- HEAVY DUTY BATTERY 750 CCA
- SINGLE GROUP 31 BATTERY

ALTERNATOR

- 145 AMP ALTERNATOR
- DELCO BRAND

STARTING SYSTEM

- DELCO 12 VOLT STARTER - SERIES 29 MT WITH OVER-RUNNING CLUTCH AND SOLENOID-CONTROLLED
- SLIDING PINION

STEERING

- POWER STEERING WITH DELPHI TILT COLUMN AND 4 SPOKE WHEEL
- 50-DEGREE WHEEL CUT ANGLE
- ZF VARIABLE RATIO STEERING GEAR
- ZF BELT-DRIVEN STEERING PUMP 1.84 GPM MIN FLOW / 3.17 GPM MAX FLOW
- 16.6 : 1.0 STEERING RATIO

FUEL SYSTEM

- FUEL TANK 151L, 40 GAL C/MNT
- FUEL TANK TYPE: SINGLE STEEL TANK MOUNTED IN BETWEEN FRAME RAILS BEHIND REAR AXLE
- FUEL HOSES: FLUROCOMP TEFLON
- FUEL PUMP: DELPHI ELECTRIC IN-TANK FUEL MODULE
- FUEL FILTER: DELPHI FRAME MOUNTED REPLACEABLE FUEL FILTER

EXHAUST SYSTEM

- 3 INCH DIAMETER ALUMINIZED STEEL TUBING EXHAUST SYSTEM
- FORWARD AND REARWARD OF MUFFLER
- TAIL PIPE EXITS BEHIND LEFT REAR WHEEL

INSTRUMENTS

- GAUGES: ACTIA "SMART" INSTRUMENT CLUSTER WITH SPEEDOMETER, TACHOMETER, AND FUEL GAUGE PLUS DRIVER SELECTABLE LCD INFORMATION WITH DIGITAL READ OUT FOR ALL ENGINE FUNCTIONS AND VEHICLE OPERATING DATA
- NOTE: ALL GAUGES AND LIGHTS MOUNTED TO BE VISIBLE FROM DRIVER'S SEAT
- HORN: STANDARD 2-NOTE MOUNTED ON LH FIREWALL
- SPEEDOMETER: ACTIA 5 INCH DIAMETER ELECTRONIC (0-85 MPH)
- LIGHTS/WARNING: FRONT TURN SIGNALS, PARKING, HAZARD WARNING, PARK BRAKE ON, HIGH BEAM HEADLIGHTS, TURN SIGNAL INDICATORS, LOW CHARGE
- PROVISIONS DAYTIME RUNNING LAMPS
- CLEAN POWER SOURCE FOR HAND HELD COMPUTER
- PROVISIONS DAYTIME RUNNING LAMPS
- WIPER SYSTEM WINDSHIELD, PULSE
- CRUISE CONTROL AUTOMATIC, ELECTRONIC
- LED COMPATIBLE FLASHER MODULE
- 75 MPH SPEED LIMITER
- LEVER TRANS SHIFTER (REMOTE DA MT) W/PARK POS
- AIR INTAKE RESTRICTION INDICATOR

COUNTRY CODE

- UNITED STATES PROVISIONS

WARRANTY

- STANDARD LIMITED WARRANTY, CHASSIS: 3 YEARS - 36,000 MILES - INCLUDING 24 HOUR ROADSIDE ASSISTANCE

VEHICLE DIMENSIONS

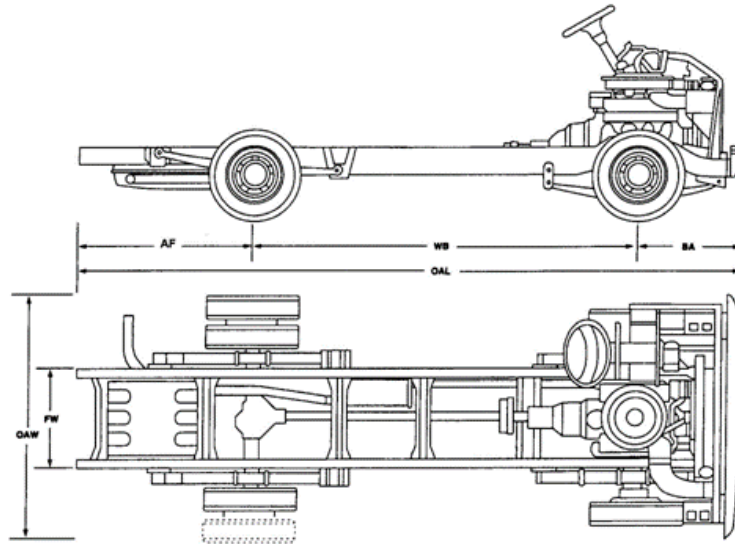

MODEL		W31042
WHEELBASE (in)	WB	133
OVERALL LENGTH (in)	OAL	236.3
OVERALL WIDTH (in) (SRW and DRW)	OAW	92.7
FACE BAR TO FRONT AXLE (in)	BA	36
REAR AXLE TO END OF FRAME (in)	AF	69.8

FRAME SPECIFICATIONS

MODEL	SIDE RAIL DIMENSIONS			SECTION MODULUS RAILS ONLY (in)	YIELD STRENGTH (PSI)	RBM OF FRAME	WIDTH OVER RAILS	
	WIDTH (in)	DEPTH H (in)	THICKNESS (in)				FRONT (in)	REAR (in)
W31042	2.57	7.01	0.213	5.55	32,000	177,600	28.14	33.64

FRONT AXLE SPECIFICATIONS

AXLE TYPE	WESTPORT MONO-BEAM AXLE WITH DOUBLE DROP
CAPACITY	AXLE FRONT 6,000 LB (FN9)
KPI - KPI (in)	66
WHEEL TRACK (mm)	1,968.5
SPRING TRACK (mm)	812.8
KPI (°)	9.45
KNUCKLE	LIVE SPINDLE WITH INTEGRATED CALIPER MOUNTING AND INTEGRATED TIE-ROD ARMS 9.45
WHEEL BEARINGS	MAINTENANCE FREE TIMKEN UNI-PAC (55 mm)
LUBRICANT	SEALED FOR LIFE

REAR AXLE SPECIFICATIONS

AXLE TYPE	DANA-SPICER FULL-FLOATING SPLINE ATTACH W/CAP DANA M80
WHEEL CONFIGURATION	DUAL REAR WHEELS (R05)
CAPACITY	AXLE REAR 11,000 LB (GL4)
PINION & RING GEARS	HYPOID
DIFFERENTIAL TYPE W/BEARINGS	PINION TAPERED ROLLER

SUSPENSION SPECIFICATIONS

GVWR	GVW RATING 12,000 LB (C7L)
REAR WHEELS	DUAL REAR WHEELS (R05)
FRONT AXLE CAPACITY	AXLE FRONT 6,000 LB (FN9)
FRONT SUSPENSION	SUSPENSION FRONT 5,000 LB, I-BEAM (FK5)
FRONT GAWR	5,000 LB
REAR AXLE CAPACITY	AXLE REAR 11,000 LB (GL4)
REAR SUSPENSION	SUSPENSION REAR 7,500 LB (GN6)
REAR GAWR	7,500 LB

POWER STEERING SPECIFICATIONS

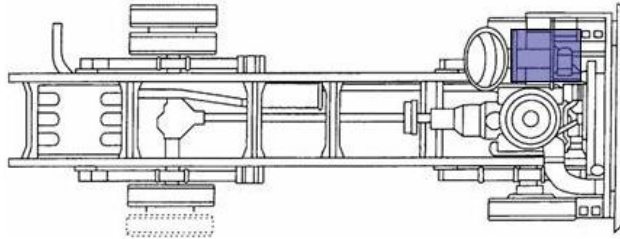

TYPE PUMP	ZF, INTEGRAL, ROTARY VANE	MOUNTING LH SIZE OF BLOCK	
W42	Driven by: Belt from Crankshaft Pulley	1.85 gpm Min. Flow Rate	3.17 gpm Max. Flow Rate

POWER BRAKE APPLICATIONS

4-WHEEL ANTI-LOCK, 4-WHEEL DISC BRAKES					PARK BRAKE TYPE	APPLY SYSTEM	
ROTOR SIZE: DIA. x TH. (in)	CALIPER PISTON DIA. (mm)	FACING CONTACT AREA/AXLE (sq. in)	PAD SIZE: LxWxTH (in)	SWEPT AREA/AXLE (sq. in)		BOOSTER TYPE	MASTER CYL. DIA. (in)
#ROTOR#	#CALIPER#	#FACINGCONTACT#	#PADSIZE#	#SWEPTAREA#	#PARKBRAKE#	#BOOSTER#	#MASTERCYL#

GM VORTEC 4.8L – V8



Engine Type	4 Cycle
Service Type	Naturally Aspirated
Engine model Number	LY2
Number of Cylinders	8
Number of Valves per Cylinder	2
Configuration	V
Bore	97.009 mm
Stroke	83.0 mm
Displacement	4.8 L/4807 cc
Compression ratio	9.5:1
Firing order	1-8-7-2-6-5-4-3
Rotational Direction	CW
Dry Weight (less clutch)	565 lbs
Fuel System	Sequential Fuel Injection
Net power @ rpm	264 hp @ 4,800 rpm
Peak torque @ rpm	295 lb-ft @ 4,400 rpm
Idle speed no-load Rated	550 rpm
Speed Full-Load	5600 rpm
Exhaust	SINGLE
Engine VIN Code	8

**2008 LY2 4.8L Small Block WCC
Heavy Duty SAE J1349* Power Test**
Active Generator and Power Steering Pump; BP = 34.1 kPa @ 4800 RPM
WITH WCC FAN LOSSES

